

INVESTIGATION OF FRONT PLOUGH FUNCTIONING STABILITY CONDITIONS WITHOUT SUPPORT WHEEL

Volodymyr Bulgakov¹, Semjons Ivanovs², Volodymyr Nadykto³, Gennadii Petrov³

¹National University of Life and Environmental Sciences of Ukraine, Ukraine;

²Latvia University of Life Sciences and Technologies, Latvia;

³Dmytro Motorny Tavria State Agrotechnological University, Ukraine
semjons@apollo.lv

Abstract. An attempt to use the vertical component of the plough traction resistance to load the tractor driving wheels led to the creation of ploughing units according to the “push-pull” diagram. In most of them, in the process of movement, the supporting wheel of the front plough, moving along the bottom of the furrow, limits the depth of ploughing. In addition, it plays the role of an element that copies the trajectory of the previous adjacent pass of the ploughing unit. In the soil conditions where it is problematic to ensure the bottom of the furrow is free from lumps of soil, the front plough support wheel is placed outside the furrow. In this case, the front plough is joined to the tractor without the possibility of their mutual agility in the horizontal plane (that is, rigidly). This article discusses the conditions for operating a front plough without a supporting wheel. With this design, the ploughing depth limiter is an adjustable limiter chain. It is joined to the tractor frame at one end and the other end to one of the lower links of the tractor front hitch linkage system (TFHLS). The total vertical additional load of the tractor’s front axle was taken as an estimated indicator of the front plough functioning. It is carried out by forces acting in the central and lower links and the restrictive chain of TFHLS. Calculations have established that the effect of the ploughing depth and the front plough specific resistance on the total vertical loading of the tractor front axle is less significant than the effect of the plough weight and its operating width. To ensure the structural reliability of elements of TFHLS, the inclination angle of its lower links must be in the range of 0-5°. The inclination angle of the central link of this system can vary between 25-30°.

Keywords: “push-pull” unit diagram, tractor front hitch linkage system, lower links, central (top) link, draft.

Introduction

During the operation of a conventional ploughing unit, vertical loads are distributed along the tractor axles. Its essence lies in the fact that under the influence of the plough traction resistance, which in the longitudinal-vertical plane inclines the horizon, the tractor rear axle is loaded, and the front one, on the contrary, is unloaded [1; 2]. To eliminate this phenomenon, ballast weights are usually mounted on this axle. The modern method of their calculation involves using appropriate software [3, 4]. However, it should be noted that adding a ballast weight to the tractor reduces its slippage while increasing the fuel consumption and soil compaction [5]. In this regard, a natural question arises: how to eliminate the unloading of the tractor’s front axle without using its ballasting?

One way to solve this problem is to use a front plough. It is hung on TFHLS and is part of the ploughing unit in the “push” mode. With the rear-mounted plough, which operates in the “pull” mode, we generally get a machine-tractor unit of the “push-pull” design diagram. According to the algorithm proposed in the monograph [6], the using essence of the frontal plough is analytically depicted as follows:

$$\Delta N \Rightarrow \Delta G \Rightarrow \Delta P \Rightarrow \Delta B \Rightarrow \Delta W$$

This algorithm is interpreted as follows. Due to the presence of a front-mounted plough, an additional, vertically directed force ΔN acts on the tractor front wheels. Its manifestation is due to the action of the frontal plough structural mass and the vertical component of its traction resistance.

The consequence of the force ΔN action is an increase in the tractor mass (ΔG) and draft (ΔN). An increase in the traction properties of the latter creates potential opportunities for increasing the ploughing unit operating width (ΔB). As a result, there is a real opportunity to increase its performance (ΔW).

But to what extent this can be implemented in practice depends on the correct choice of the plough design parameters and the diagram of its joining to the tractor. Two such diagrams are currently known. The first is characterized by a free (unlocked) vertical hinge of the front plough frame. Due to this, during the movement of the machine-tractor unit, it performs its own (and independent) oscillations in the horizontal plane relative to the tractor. However, these fluctuations cannot be called entirely random. In practice, their nature is somewhat due to the curvature of the ploughing unit previous pass furrow

trajectory. In the process of ploughing, tracking this trajectory is carried out by the support wheel of the front plough. But in addition to monitoring the curvature of the furrow trajectory, this wheel also performs another technological function: setting the ploughing depth. At the same time, in the south of Ukraine soil conditions, a clean bottom of the furrow is far from always obtained during ploughing. Usually, after the passage of the arable unit, lumps of soil with a diameter of up to 10-15 cm remain on it, which cannot be destroyed by the front plough supporting wheel. After the first one hits such a block, the frame of the second one rises in the vertical direction. As a result, this leads to deepening of the front plough bottoms with a subsequent increase in the unevenness of the ploughing depth. The way out of this situation is to use the location of the front plough supporting wheel outside the furrow, that is, on the surface of the cultivated field [6]. But since it no longer tracks the furrow trajectory of the ploughing unit previous pass, the joining of the front plough to the tractor in the horizontal plane can be rigid [7]. Studies have shown that the correct location of the support wheel on the front plough is very problematic. When solving it, the inclination angles play a significant role and the installation height of the central and lower links of TFHLS [8]. Moreover, when choosing the installation coordinate of the front plough supporting wheel, one should consider such a parameter as the latter's length. Considering the consumption of materials for the wheel manufacture and the mechanism for regulating the height of its placement on the plough frame, the question arises: is it possible to completely abandon its (wheel) use?

Despite such constructive solutions in Europe and the world, there are very few scientific studies on this issue. In fact, there are no scientifically based recommendations for the correct choice of parameters for a front plough without a supporting wheel. The dynamics of the ploughing unit movement according to the "push-pull" diagram is analyzed in one of the scientific works [9]. The main results of this research emphasize that the use of a front plough causes an increase in the role of the tractor front axle in the draft it creates. As a result, the ploughing time of 1 hectare has decreased by 34%, while reducing the specific fuel consumption by 26.5%. But in this ploughing unit, the front plough, like the rear-mounted one, is equipped with not one but two support wheels.

In the work [10], researchers considered an arable unit with a front plough without a support wheel. Their research aimed to develop a computer program for calculating the forces acting in the central and lower links of TFHLS. At the same time, the design proposed by the authors does not indicate a mechanism that limits the front plough depth without a supporting wheel. Because of this, at least one component is missing in the diagram of forces acting on the plough, which reflects its effect on the tractor front axle. For the solution to the problem posed in this article, this, in principle, is not so important. But for analyzing the dynamics of the front plough influence on the tractor, such a simplification of the active forces diagram is hardly suitable for further in-depth scientific analysis. This remark is also supported by the fact that the diagram of forces presented in the work [10] does not contain the inclination angle of the lower links of TFHLS. And as established by our research [6], the contribution of this design parameter to the distribution of active forces and reactions acting in the frontal plough is very significant.

Because of the preceding, this work aims to develop an analytical apparatus for the theoretical assessment of the technical feasibility and efficiency of the front plough without a supporting wheel.

Theoretical premises

The basis of the theoretical study is the analysis of the design parameter influence of a frontal plough without a supporting wheel on fulfilling the conditions for its static equilibrium state in the longitudinal-vertical plane (Fig. 1). Instead of a support wheel, the front plough is fitted with a length-adjustable flexible mechanical link (chain) FK . At point F , it is joined to the tractor frame, and at point K , it is joined to the lower links of its front hitch linkage system. The following forces act on the front plough from the side of the tractor and the soil background (Fig. 1): weight (G , kN); concentrated at point D vertical (R_v , kN) and horizontal (R_h , kN) components of the plough traction resistance; tractor action forces on the plough through the central link (R_v , kN) and lower links (P_n , kN) of its front hitch linkage system; reaction force (P_d , kN) acting in the FK link. The diagram of forces (Fig. 1) is drawn up, considering the assumption that all working bottoms of the front plough can be represented by one "equivalent" bottom. The legitimacy of this assumption is due to almost the same conditions for the functioning of all plough bottoms. Such a schematic technique is quite common in research practices [1; 7; 9-11].

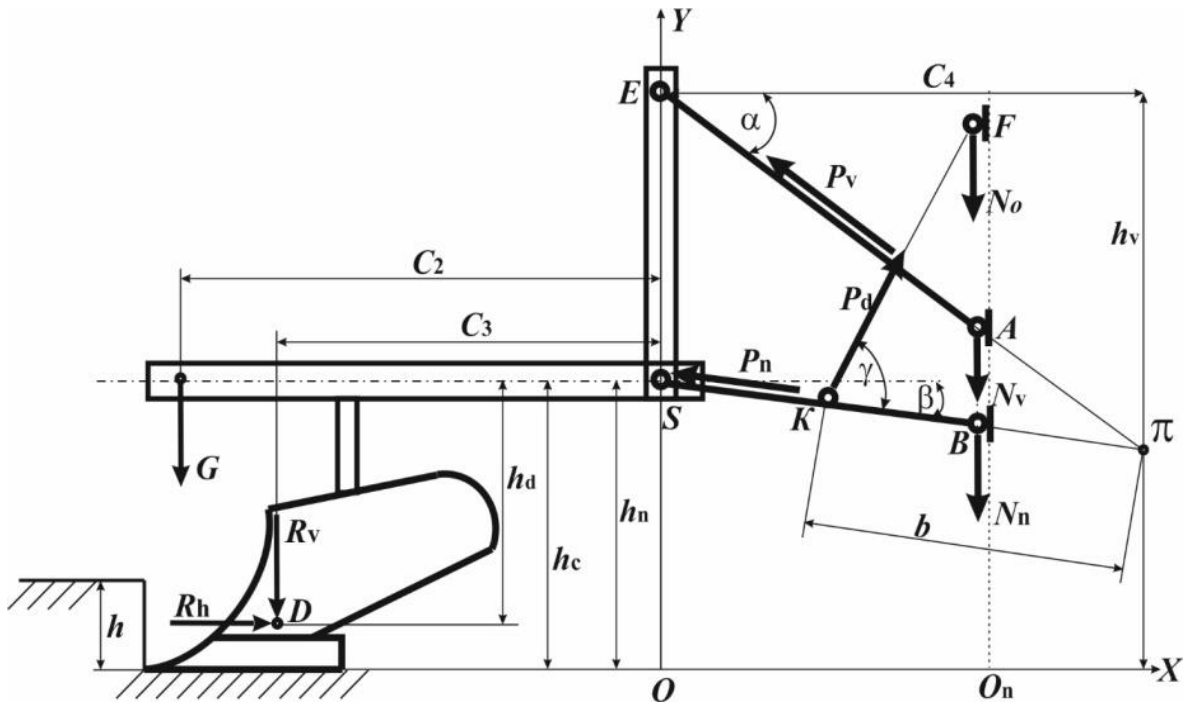

Fig. 1. Diagram of forces acting on the front plough in the longitudinal-vertical plane

Of the forces listed above, only three are unknown: P_v , P_n and P_d . Force R_h can be found from the following equation:

$$R_h = k \cdot B \cdot h \tag{1}$$

where k – plough specific resistance, $\text{kN} \cdot \text{m}^{-2}$;
 B – front plough operating width, m;
 h – ploughing depth, m.

It is known from practice that the vertical component of the plough traction resistance R_v is approximately 20% of its horizontal component R_h . Hence:

$$R_v = 0.2 \cdot k \cdot B \cdot h \tag{2}$$

To determine the unknown reactions P_v , P_n and P_d , it is enough to compose and solve a system of three static equations in the form of force projections on the OX and OY axes, as well as the sum of moments relative to point π (Fig. 1). Taking into account equations (1) and (2), we obtain dependencies that fully reflect the operating conditions of the front plough without a supporting wheel in the longitudinal-vertical plane:

$$\begin{cases} k \cdot B \cdot h - P_n \cdot \cos \beta - P_v \cdot \cos \alpha + P_d \cdot \sin \beta = 0 \\ P_n \cdot \sin \beta + P_v \cdot \sin \alpha + P_d \cdot \cos \beta - G - 0.2 \cdot k \cdot B \cdot h = 0 \\ G \cdot (C_2 + C_4) + k \cdot B \cdot h \cdot [0.2(C_3 + C_4) + h_d - C_4 \cdot \tan \beta] + P_d \cdot b = 0 \end{cases} \tag{3}$$

where α and β – central and lower links angle inclination of TFHLS;
 C_2 , C_3 , C_4 , h_d , and b – design parameters, the nature of which is clear from Fig. 1.

Methods and materials

To further use the equations system (3), we determine the values of the quantities included. As long-term practice shows, in the soil conditions of the south of Ukraine, the plough specific traction resistance varies within $k = 50\text{-}60 \text{ kN} \cdot \text{m}^{-2}$. At higher values of this parameter, the quality of ploughing is unacceptable.

In this study, a double-furrow frontal plough is considered. The operating width of its bottom is 0.35 m. According to the “push-pull” diagram, a tractor with a rear-mounted four-furrow plough is used for its aggregation with a nominal traction force of 30-40 kN. With this in mind, for theoretical studies,

the following values of the design parameters of this front plough and TFHLS (Fig. 1) are taken (Table 1).

Table 1

Initial calculated data

Parameter	Dimension	Value
B	m	0.70
G	kN	4.5
C_2	m	1.3
C_3	m	0.5-1.5
h_c	m	0.72
BO_n	m	0.66
AB	m	0.65
BS	m	0.82
SK	m	0.32
FB	m	0.70
KB	m	0.50

The remaining design parameters included in the system of equations (3) are functions of the angles α and β :

$$C_4 = \frac{h_v - h_n}{\tan \alpha - \tan \beta}, \quad (4)$$

$$h_n = BO_n + BS \cdot \sin \beta, \quad (5)$$

$$h_v = BO_n + BS \cdot \cos \beta \cdot \tan \alpha, \quad (6)$$

$$h_d = h_c - 0.3 \cdot h, \quad (7)$$

$$b = \frac{h_v - h_n}{\tan \alpha - \tan \beta} - SK, \quad (8)$$

$$\gamma = \arctan \frac{FB - KB \cdot \sin \beta}{KB \cdot \cos \beta} + \beta. \quad (9)$$

During the ploughing machine-tractor unit operation, the impact of the tractor on the front plough is represented by the forces P_v , P_n and P_d . The back reaction of the plough to the tractor is expressed by forces that are equal in absolute value to the above but opposite in direction. The vertical components of these forces are N_v , N_n and N_o (see Fig. 1). Their total action represents the desired additional load N_s of the tractor's front axle, the change vector of which is as follows:

$$N_s = N_v + N_n + N_o \rightarrow \max \quad (10)$$

or

$$N_s = P_v \cdot \sin \alpha + P_n \cdot \sin \beta + P_d \cdot \sin(\gamma - \beta) \rightarrow \max \quad (11)$$

The preceding shows that the choice of the frontal plough design parameters, included in the equations system (3), should be carried out in the direction of fulfilling condition (11). The greater the force value N_s , the more influential the front plough is in the vertical loading of the tractor front axle. The value of this additional load is essential for improving the traction and coupling properties of the tractor and ensuring the controllability and stability of the ploughing unit movement based on it [12].

Results and discussion

The theoretical calculation results of the equations system (3) show that the total additional load N_s of the tractor's front axle depends only on four parameters: i) plough width (B); ii) plough weight (G); iii) ploughing depth (h); iv) specific resistance coefficient of the plough (k). Relative to other parameters, the value of the indicator N_s is invariant. If the functional dependence $N_s = f(B)$ is invariant relative to

the change in the parameter G , then its graphical interpretation would look like a straight line 1 (Fig. 2). The nature of its change shows that with an increase in the parameter B three times (from 0.35 to 1.05 m), the vertical load on the front axle of the tractor increases by 1.6 times (from 3.46 to 5.39 kN).

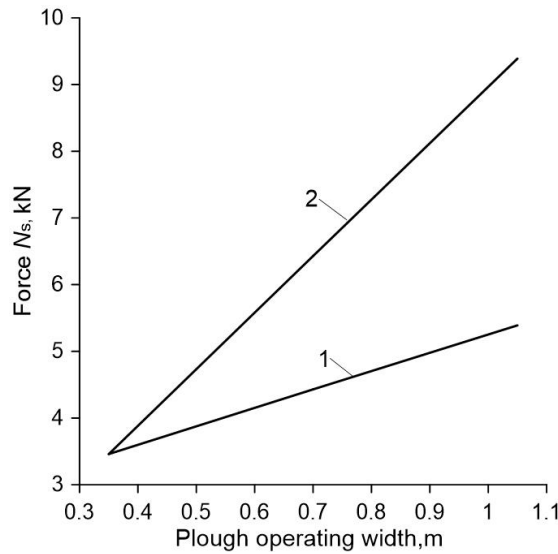

Fig. 2. Influence of the parameter B on the indicator N_s without change (1) and with change (2) of the parameter G ($\alpha = 15^\circ$; $\beta = 0^\circ$; $h = 0.25$ m; $k = 55$ kN·m⁻²)

In fact, it should be taken into account that a change in the front plough operating width causes a corresponding change in its weight. In this case, the dependence $N_s = f(B)$ is combined and appears as a straight line 2 (see Fig. 2). From its analysis, we see that the same increase in the plough operating width by a factor of three leads to an increase in the additional vertical load of the tractor front axle by 2.7 times (from 3.46 to 9.39 kN).

As noted above, the parameter B for the front plough is assumed to be fixed and equal to 0.70 m. Under the condition $\alpha = 15^\circ$, $\beta = 0^\circ$, $h = 0.25$ m and $k = 55$ kN·m⁻², this provides additional loading of the tractor's front axle to the level of 6.43 kN (line 2, Fig. 2). Subsequently, as shown in the work [13], this has a positive effect on the trajectory indicators of the ploughing unit movement according to the "push-pull" diagram with a frontal double-furrow plough.

The influence of the ploughing depth (h) on the total vertical load of the tractor front axle (N_s) is not as significant as the change in the parameters B and G . With an increase in the parameter h by 1.5 times (from 0.20 to 0.30 m), the N_s indicator increases only by 13% (Fig. 3).

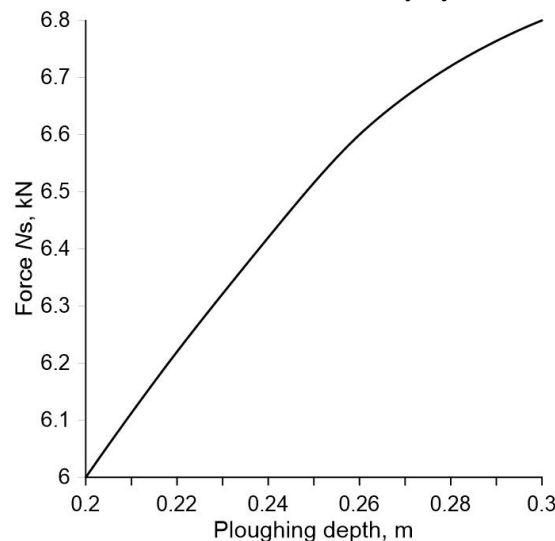

Fig. 3. Dependence of the force N_s on the ploughing depth

Almost the same result is obtained when changing the plough specific resistance coefficient (Fig. 4). With an increase in this parameter by 18% (from 55 to 65 kN·m⁻²), the N_s indicator, respectively, increases by only 6%.

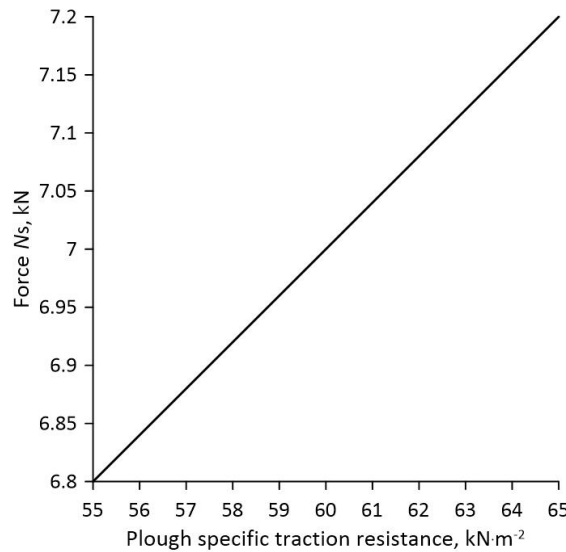

Fig. 4. Dependence of the force N_s on the plough specific traction resistance coefficient

The reason for this result is, in our opinion, the following. The impact of the front plough weight on the N_s indicator is more significant because it acts directly on the tractor front axle. Changing the parameters B and h affects this axle indirectly: through the vertical component of the plough traction resistance. The nature of the relationship between the latter and these two parameters is known and quite understandable.

As already emphasized above, changing the parameters included in the system of equations (3), except for the considered B , G , h and k , does not affect the value of the additional vertical load of the front axle (N_s). At the same time, the forces P_v , P_n and P_d , which respectively form the indicator N_s , change while maintaining the following condition:

$$N_s = P_v \cdot \sin \alpha + P_n \cdot \sin \beta + P_d \cdot \sin(\gamma - \beta) = \text{const.} \quad (11)$$

Based on this, it is appropriate to know the dynamics changes in each of these forces. The availability of such information will make it possible to select the parameters of TFHLS in such a way as to prevent the power overload of its central and lower links, as well as other elements. Thanks to theoretical studies, it has been established that with an increase in the inclination angle of the TFHLS central link (α) and with a constant value of the inclination angle of the lower ones ($\beta = 0$), the force in the restrictive chain (force P_d , Fig. 1) increases (line 3, Fig. 5). The dynamics of this process are as follows: with an increase in the angle α by six times (from 5 to 30°), the force P_d doubles (from 9 to 18 kN).

Under the same conditions, the change dynamics of forces acting in the central (P_v) and lower (P_n) links of TFHLS are qualitatively and quantitatively different. In general, the process $P_v, P_n = f(\alpha)$ is characterized by two zones. The delimitation of these zones is carried out at point A. The method of its determination is quite fully described in the work [14]. In the first of them, an increase in the argument (parameter α) causes a sharp decrease in the function, that is, the forces P_v and P_n (curves 1 and 2, Fig. 5). The considered function decreases less intensively in the second zone.

As follows from the analysis of Fig. 5, with an increase in the value of the angle α from 5.0 to 12.5° (that is, by 7.5°), a decrease in the values of the forces P_v and P_n by more than two times is observed. With a further increase in the angle α to 30°, the force values P_n decrease by almost 1.9 times.

But, if in the first zone this decrease occurs in the range of the angle α from 5 to 12.5°, then in the second – in a much wider range: from 12.5 to 30°. That is why the first zone of the two-zone process under study has a more intense character of the change in the function of the argument. This result

practically does not contradict the data obtained in the study of the kinematics and dynamics of the frontal plough used with the caterpillar tractor [15].

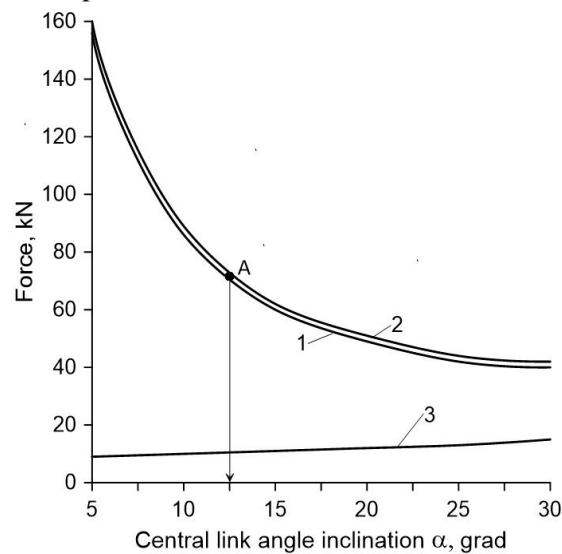

Fig. 5. Dependence of forces $P_n(1)$, $P_v(2)$, $P_d(3)$ on the angle α

Now let us analyze the situation when the lower links of TFHLS are located at an angle $\beta = 5^\circ$. In this case, an increase in the inclination angle of the TFHLS central link to 30° causes a qualitatively and practically quantitatively similar nature of the change in the values of the forces P_v , P_n and P_d in comparison with the option when $\beta = 0^\circ$ (see Fig. 5).

As a result, we have the following. The inclination angle of the TFHLS central link (α) has a greater effect on the dynamics of changes in the forces P_v , P_n and P_d than the inclination angle of the lower links (β). An increase in the angle α , in turn, mainly affects the change in the forces acting in the central and lower links of the tractor's hitch linkage system. The growth of the force acting in the restrictive chain is less intense. Moreover, the general (total) change in the values of these forces is such that condition (11) is satisfied.

From the analysis of Fig. 5, we see that significantly greater forces act in the links of TFHLS than in the limiting chain of the front plough. To reduce them while maintaining condition (11) and ensuring the structural reliability of the elements of TFHLS, the inclination angle of its central link (α) should be as large as possible. A rational limitation of this increase is such a design parameter as the height SE of TFHLS (Fig.1). The greater this height, the larger the front plough, which is undesirable. Almost the same conclusion regarding the longitudinal dimension of the plough is reached by the authors in the work [16].

Quite acceptable, in our opinion, is the condition under which the inclination angle of the central link of TFHLS (α) will be within $25-30^\circ$. In this case, the forces in the central and lower links will be close to the lowest (at 40 kN). The force P_d acting in the restrictive chain of the plough will be at a level not exceeding 20 kN. And this is also quite an acceptable result.

The inclination angle of the lower links of TFHLS can be changed to $0-5^\circ$. The disadvantages of this parameter value less than 0° (i.e. when the angle β is negative) are shown in [6]. An increase in the value of the angle β beyond the specified range (i.e. more than 5°), as shown above, does not have a significant effect on the changes in dynamics in the forces P_v , P_n and P_d . But overall, the plough dimensions simultaneously increase, which is undesirable.

Conclusions

A system of analytical equations for the equilibrium state of a frontal plough without a support wheel has been developed, which makes it possible to assess the influence degree of its design parameters on the total vertical additional load value of the tractor front axle. Analysis of the solution of these equations made it possible to establish that:

1. additional loading of the tractor front axle (N_s) is the sum of the forces' vertical projections acting in the central (P_v) and lower (P_n) links, as well as in the limiting chain (P_d) of the tractor hitch linkage system. The value N_s depends on the working width (B), the weight (G), the specific resistance coefficient of the plough (k) and the ploughing depth (h). Relative to the other parameters included in the system of equations (3), the value of the indicator N_s is invariant;
2. the value of the additional vertical load of the tractor front axle with an increase in the width of the front plough without the supporting wheel changes according to a linear law. Being functionally related to the plough weight, the growth of the parameter B from 0.35 to 1.05 m causes an increase in the value of the indicator N_s by 2.7 times;
3. the influence of the ploughing depth (h) and the specific resistance of the front plough (k) on the total vertical additional load of the tractor front axle is less significant than the influence of the plough weight and its operating width. This is because the functionally related parameters B and G affect the value of the indicator N_s directly and the parameters h and k indirectly through the vertical component of the front plough traction resistance;
4. the inclination angle (α) of the central link of the tractor front hitch linkage system has a more significant influence on the dynamics of changes in the forces P_v , P_n and P_d than the inclination angle of the lower links (β). At the same time, an increase in the angle α mainly affects the change in the forces acting in the central and lower links of the tractor hitch linkage system. The growth of the force acting in the restrictive chain is less intense. The general (total) change in the values of these forces is such that the condition $N_s = \text{const}$ is satisfied;
5. for a tractor with a front plough, which has not a support wheel, the inclination angle rational value of the hitch linkage system central link is 25-30°, and the lower ones 0-5°.

Author contributions

All the authors have contributed equally to creation of this article.

References

- [1] Macmillan R. H. The mechanics of tractor-implement performance. Agricultural Engineering International: CIGR Journal, 2003.
- [2] Bulgakov et al. Theoretical background for increasing grip properties of wheeled tractors based on their rational ballasting. *Agraarteadus: Journal of Agricultural Science*, 2019, vol. 30, Issue 2, pp. 78-84, DOI: 10.15159/jas.19.07.
- [3] Pranav P. K., Pandey K. P. Computer simulation of ballast management for agricultural tractors. *Journal of Terramechanics*, 2008, vol. 45(6), pp. 185-192.
- [4] Janulevičius A., Giedra K. Tractor ballasting in field work. *Mechanika*, 2008, vol. 5(73), pp. 27-34.
- [5] Moinfar A. M. et al. The effect of the tractor driving system on its performance and fuel consumption. *Energy*, 2020, Vol. 202, Art. 117803.
- [6] Bulgakov V.M., Kravchuk V.I., Nadykto V.T. Aggregation of Ploughs. Kyiv, 2008, 152 p. (In Ukrainian).
- [7] Bulgakov V. et al. Theoretical research into the stability of motion of the ploughing tractor-implement unit operating on the 'push-pull' principle. *Agronomy Research*, 2017, vol. 15, pp. 1517-1529, DOI: 10.15159/AR.17.069.
- [8] Kistechok O.D., Nadykto V.T. Terms stability motion of deepening frontal plough. *Scientific bulletin of the Tavria State Agrotechnological University*, 2013, vol. 1, is. 3, pp. 3-10.
- [9] Csatos C. The Frontal and Rear Ploughs Effects on 4WD Tractors, in: *The 3rd International Conference on "Computational Mechanics and Virtual Engineering"*, 2009, pp. 194-199.
- [10] Singh N., Pandey K. Development of Visual Basic Program to Design Front Mounted Three-Point Linkage for Higher Power Tractors. *Advances in Research*, 2017, vol. 11, pp. 1-10, DOI: 10.9734/air/2017/35767.
- [11] Troyanovskaya et al. Directional Stability of an Agricultural Tractor. *FME Transactions*, 2021, vol. 49, p. 456-462, DOI: 10.5937/fme2102456T.
- [12] Bulgakov et al. Theoretical consideration of the controllability indicator of machine-tractor unit movement. *Acta Technologica Agriculturae*, 2017, vol, 20, pp. 11-18, DOI: 10.1515/ata-2017-0003.

- [13] Kistechok O. Working indicators of arable machine-tractor unit which created according to the “push-pull” scheme. Design, production and operation of agricultural machines, 2016, vol. 46, pp. 144-154. (In Ukrainian).
- [14] Velichko E.V., Nadykto V.T. Determining the optimum points of two classes of two-band functions. Engineering Journal: Science and Innovation, 2014, vol. 5(29), pp. 1-7. (In Russian).
- [15] Gorin G.S., Vashchula A.V. Equilibration of an arable unit on the basis of a caterpillar tractor in the longitudinal-vertical plane. Belarus Sciences National Academy News, 2008, vol. 1, pp. 89-95. (In Russian).
- [16] Boykov V.M., Startsev S.V., Pavlov A.V., Okas K.K. Substantiation for kinematic length of the front plow ripper. Agrarian scientific journal, 2016, vol. 12, pp. 53-55. (In Russian).